

# Easy Compact Grader

Simple & Quick grading for food products

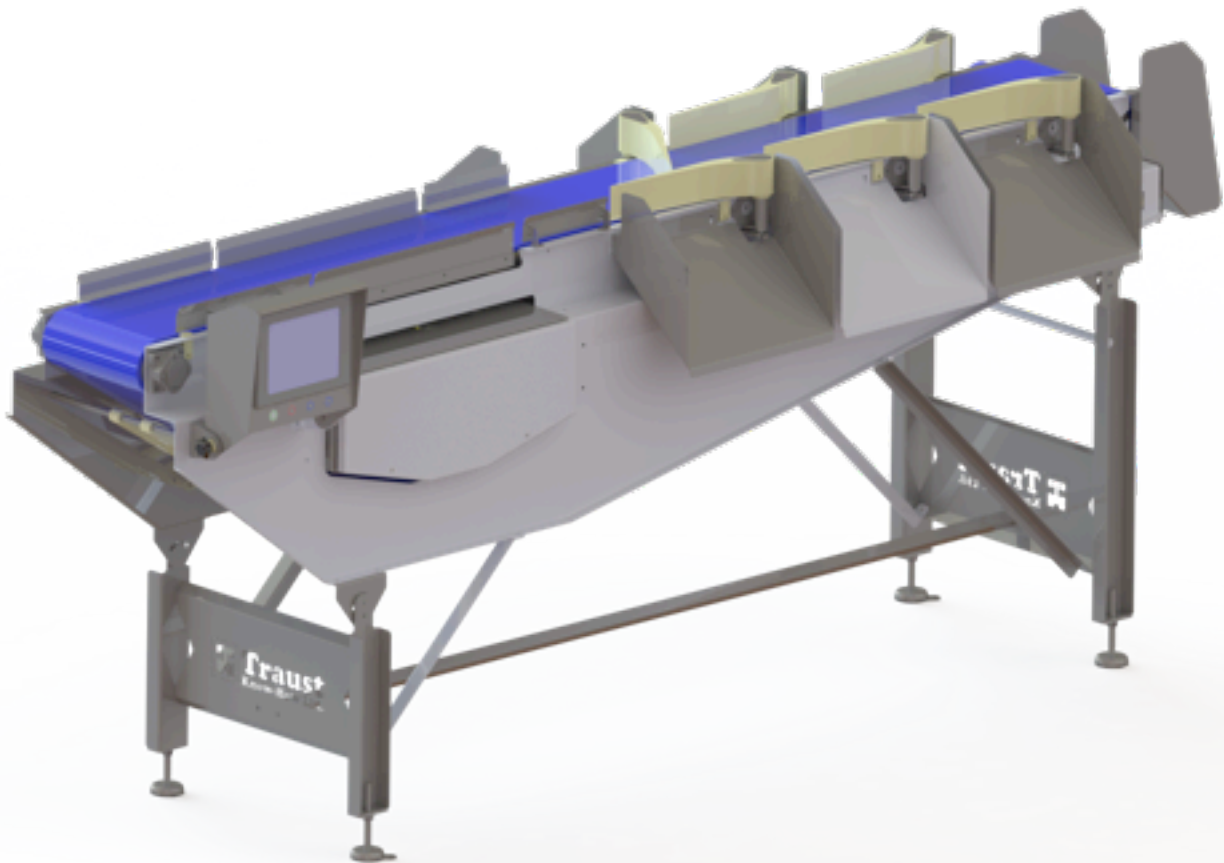

- Easy automatic operation
- Fast & accurate grading
- Simple batching
- Easy installation
- Safe & easy to operate



# Advanced Compact Grading

## Gentle sorting and batching for any food product



Capable of grading and batching 6+1 different weight categories.



The Easy Compact Grader is robust with a user-friendly touch screen and Ethernet connection for data logging. The highly economical Easy Compact Grader is a part of a line of low-cost advanced processing equipment that offers essential high-tech machine. Suitable for simple grading and batching of a wide variety of products, the grader is designed to fulfill the needs of small and medium sized companies. The Easy Compact Grader is ideal as an add-on for larger companies requiring a machine that can handle temporary or seasonal overflow needs that do not

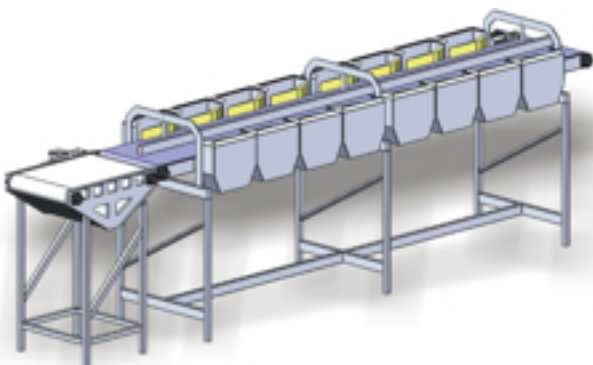

Fresh Product Grader

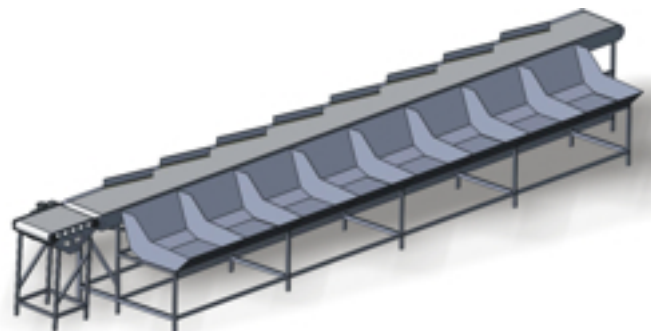

Salt Fish Grader

# Easy Grading & Batching

Fast precision grading, handles raw material gently

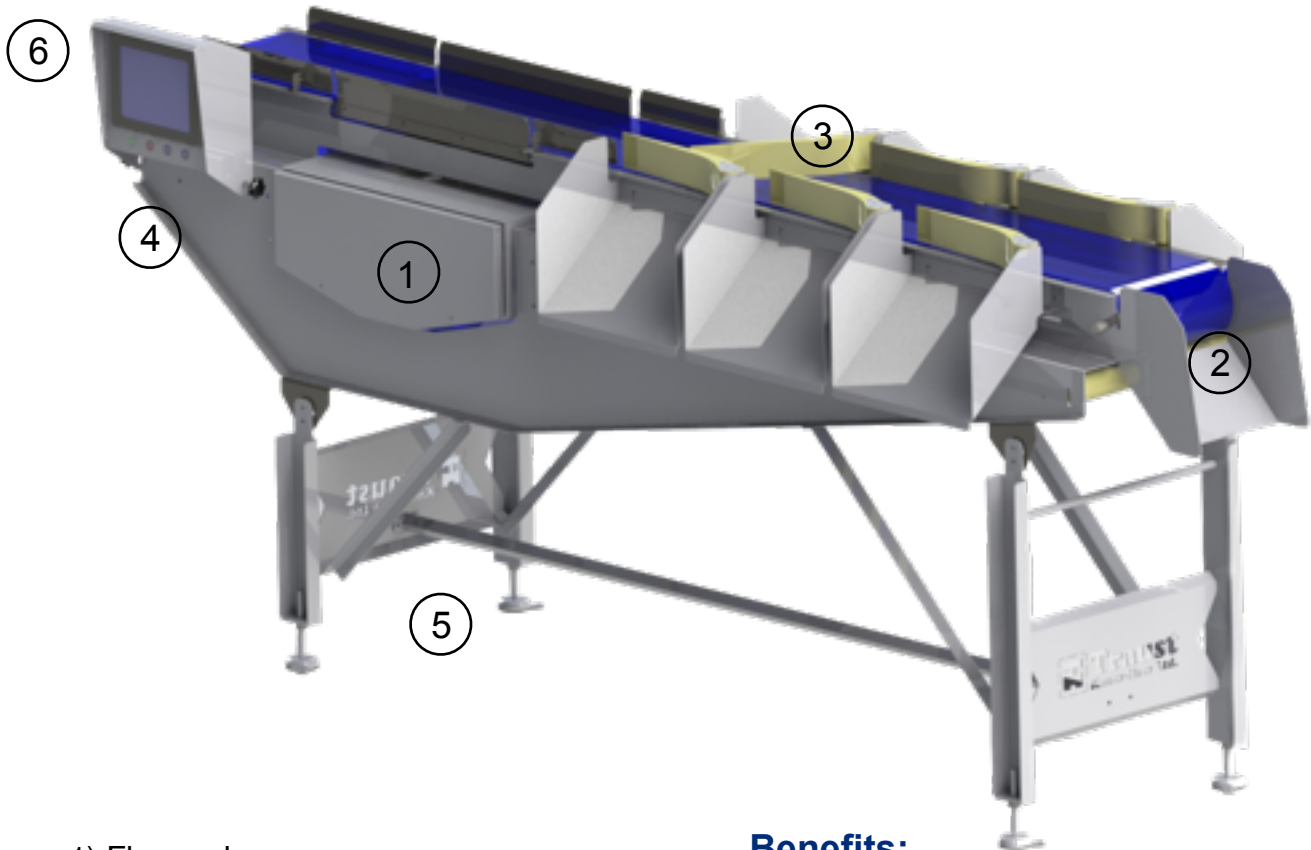

- 1) Flowscale
- 2) Conveyor
- 3) 6 pcs. Grading gates
- 4) Conveyor motor
- 5) Adjustable legs
- 6) Touch screen

## Benefits:

- ◆ Fast precision grading
- ◆ Automatic process
- ◆ User friendly interface, touch screen
- ◆ Ethernet connection
- ◆ Handles raw material gently
- ◆ High capacity grading
- ◆ Energy efficient
- ◆ Standard solution
- ◆ Easy to clean & sanitize
- ◆ Safe & easy to operate

## Operating the Easy Compact Grader ECG100

The Easy Compact Grader, ECG100, grades and batches product pieces into a maximum of 6 different categories. The arms above each gate quickly select each individual piece into the gate. When pre-determined batch has been reached, a light turns on under the gate. The operator then removes the batch and presses a button under the gate to open it again for the next batch. All data can be exported to a database with Ethernet connection.

# Easy Compact Grader

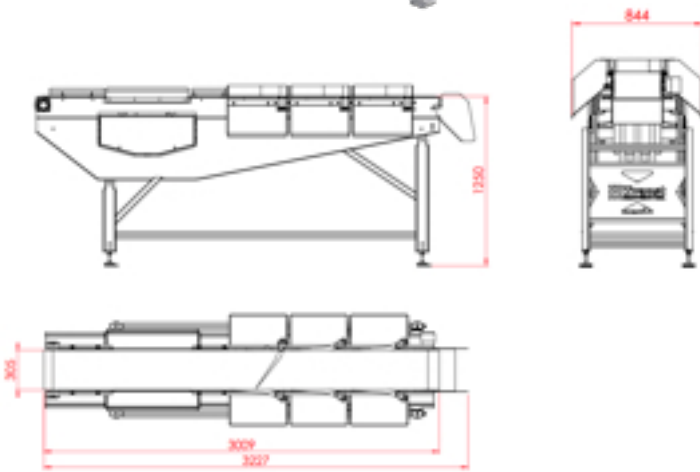
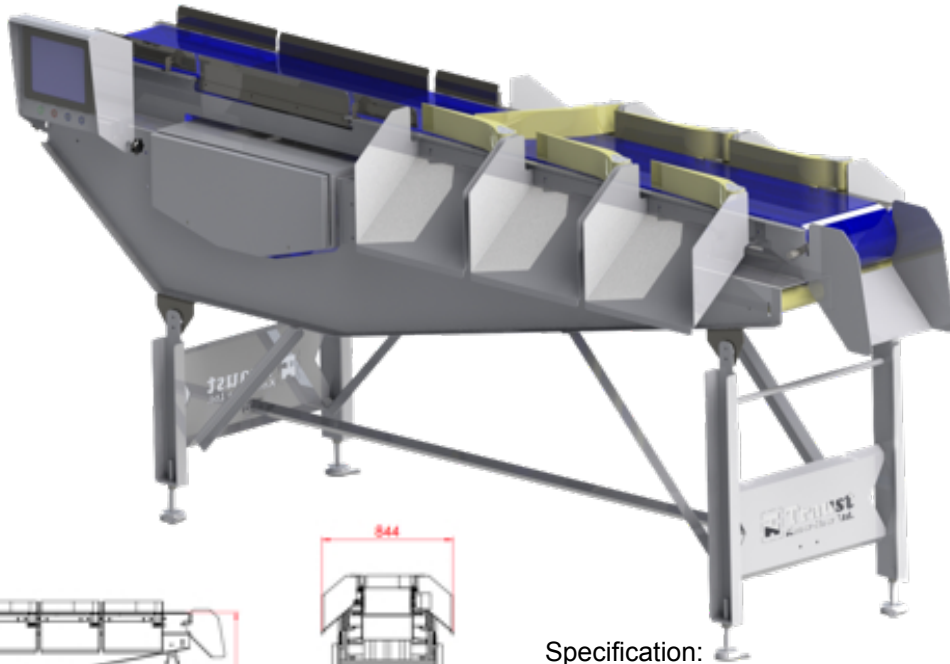

Specification:  
 Dimensions L x W x H: 1250 x 844 x 3227mm  
 Number of gates: 6  
 Accuracy: 2g for pieces under 500g, otherwise 5g  
 Capacity: 120pcs/min  
 Product length: 50mm - 450mm  
 Gate division: 460mm  
 Display: Touch screen  
 Power: 700W  
 Voltage: 1x208-230 V  
 Frequency: 50/60Hz.  
 Current: 3amp.  
 Air required: Working pressure: 6bar. 120L/min.  
 Weight: 205kg.

Available is a wide range of graders, to grade most food products

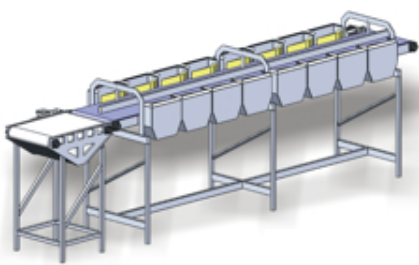

Fresh Product Grader

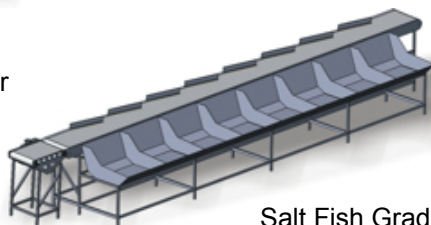

Salt Fish Grader

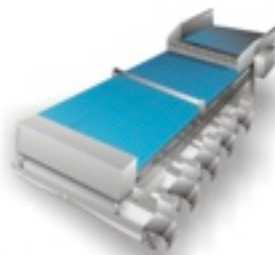

Pelagic Channel Grader



Scallop Channel Grader

## Optimize your investment with custom-made solutions

Traust Know How, Ltd., has been a leader developing fish processing equipments for over 30 years. Our qualified team of engineers with years of experience, design and develop all our fish processing plants/equipment, to suit the need of the fish processing industry around the world.



Agent North America:  
 OGO Global, LLC. Lynnwood, WA 98087 USA.  
 Office: +1-425-608-0270 or 425-242-8152  
 info@ogo-global.com www.ogo-global.com



www.traust.is traust@traust.is  
 Office phone: +354-516-3000