

Easy Compact Grader

Simple & Quick grading for food products

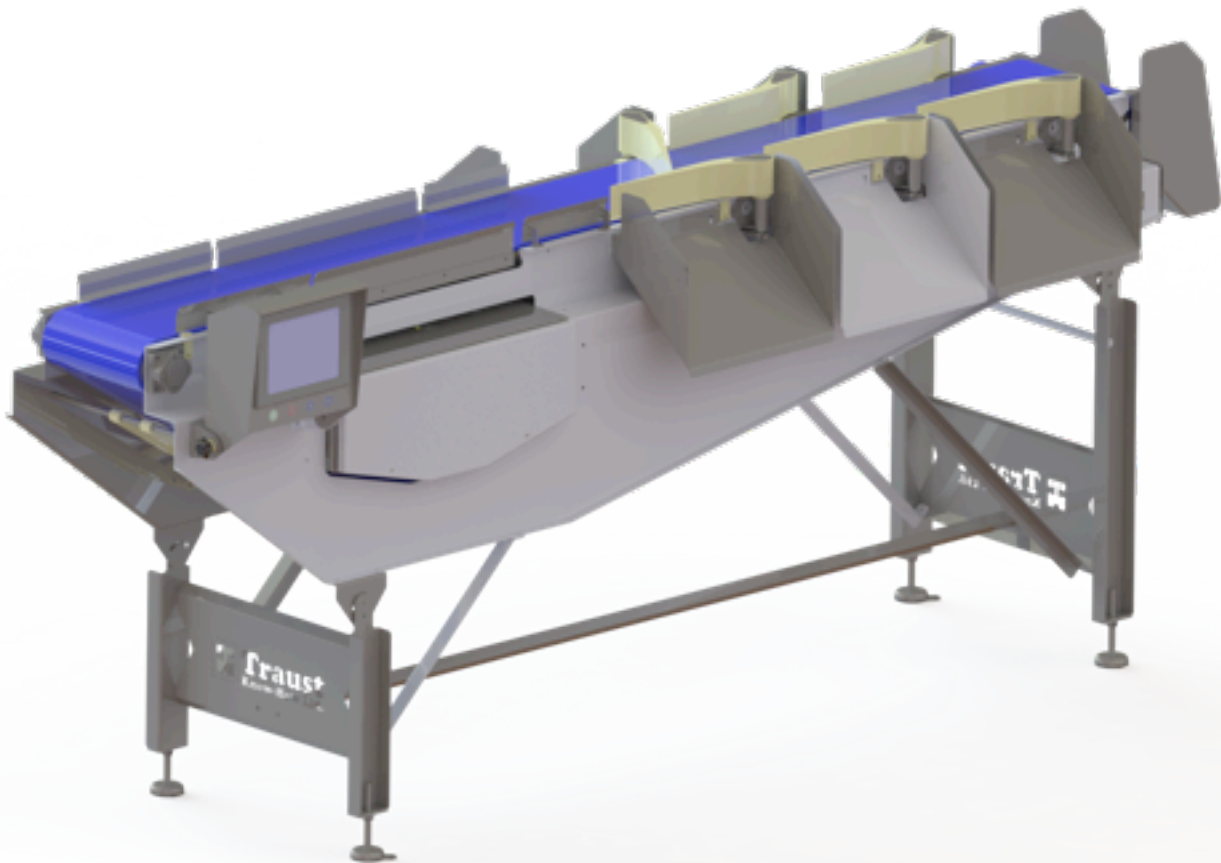

- Easy automatic operation
- Fast & accurate grading
- Simple batching
- Easy installation
- Safe & easy to operate



Advanced Compact Grading

Gentle sorting and batching for any food product



Capable of grading and batching 6+1 different weight categories.



The Easy Compact Grader is robust with a user-friendly touch screen and Ethernet connection for data logging. The highly economical Easy Compact Grader is a part of a line of low-cost advanced processing equipment that offers essential high-tech machine. Suitable for simple grading and batching of a wide variety of products, the grader is designed to fulfill the needs of small and medium sized companies. The Easy Compact Grader is ideal as an add-on for larger companies requiring a machine that can handle temporary or seasonal overflow needs that do not

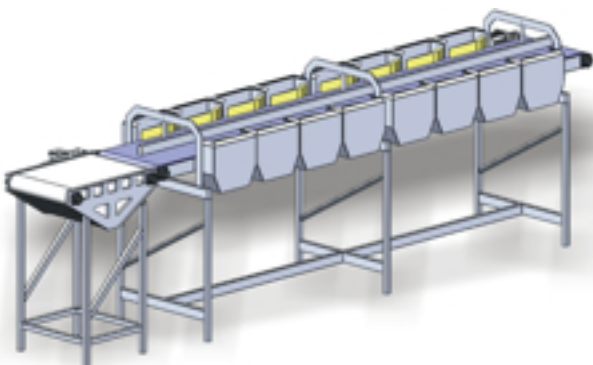

Fresh Product Grader

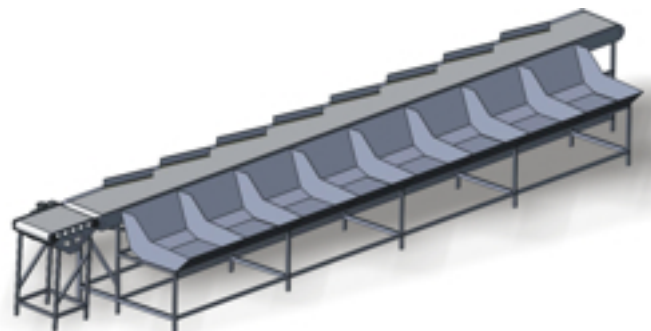

Salt Fish Grader

Easy Grading & Batching

Fast precision grading, handles raw material gently

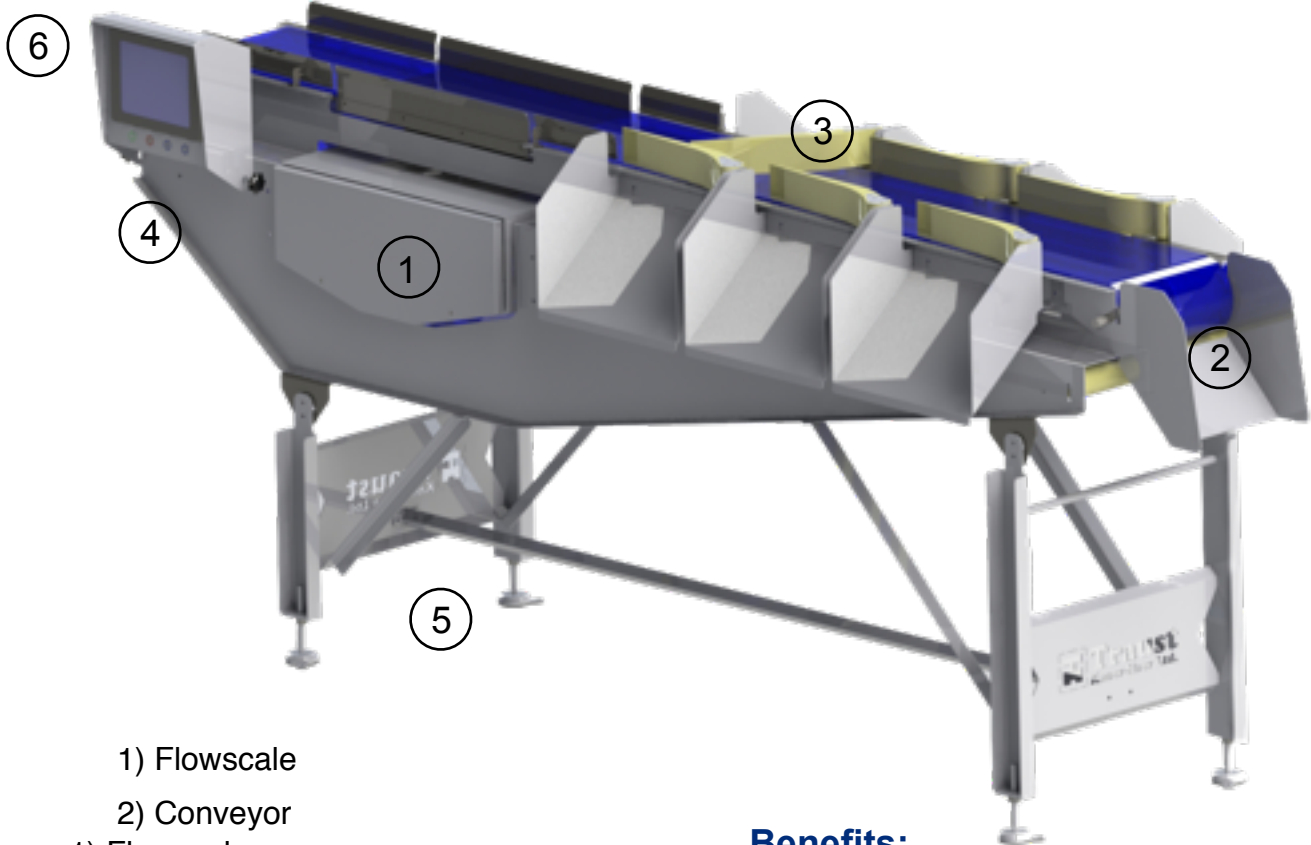

- 1) Flowscale
- 2) Conveyor
- 1) Flowscale
- 3) 6 pcs. Grading gates
- 2) Conveyor
- 4) Conveyor motor
- 3) 6 pcs. Grading gates
- 5) Adjustable legs
- 4) Conveyor motor
- 6) Touch screen
- 5) Adjustable legs
- 6) Touch screen

Benefits:

- ◆ Fast precision grading
- ◆ Automatic process
- ◆ User friendly interface, touch screen
- ◆ Ethernet connection
- ◆ Handles raw material gently
- ◆ High capacity grading
- ◆ Energy efficient
- ◆ Standard solution
- ◆ Easy to clean & sanitize
- ◆ Safe & easy to operate

Operating the Easy Compact Grader ECG100

The Easy Compact Grader, ECG100, grades and batches product pieces into a maximum of 6 different categories. The arms above each gate quickly select each individual piece into the gate. When pre-determined batch has been reached, a light turns on under the gate. The operator then removes the batch and presses a button under the gate to open it again for the next batch. All data can be exported to a database with Ethernet connection.

Easy Compact Grader

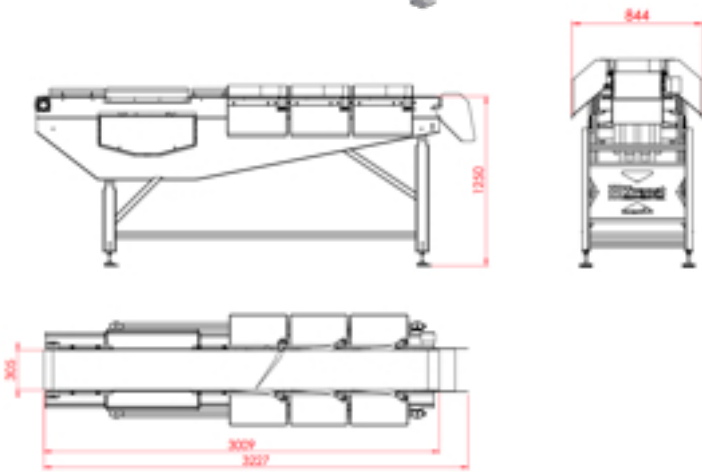
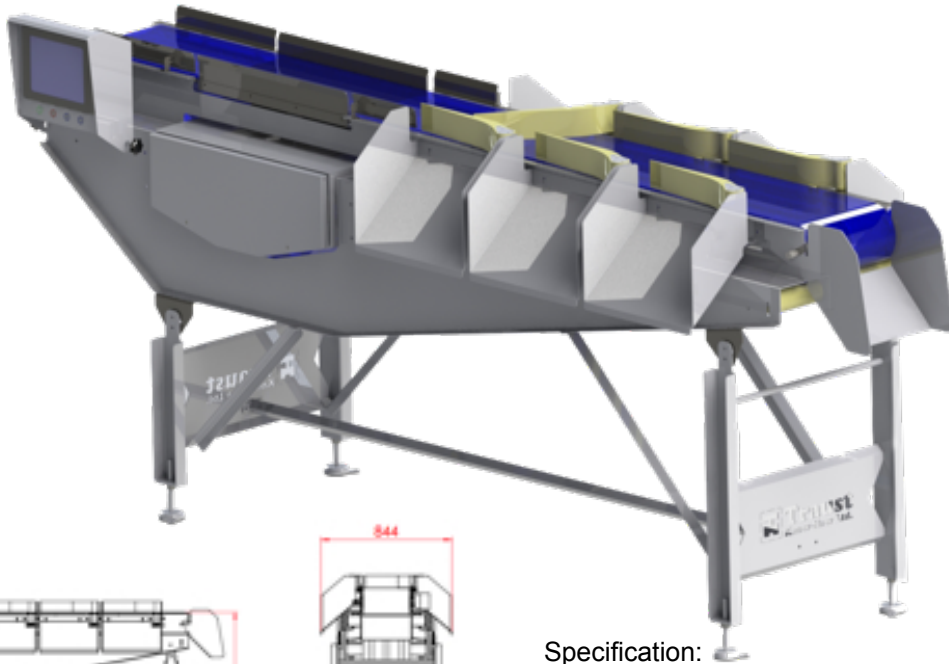

Specification:
 Dimensions L x W x H: 1250 x 844 x 3227mm
 Number of gates: 6
 Accuracy: 2g for pieces under 500g, otherwise 5g
 Capacity: 120pcs/min
 Product length: 50mm - 450mm
 Gate division: 460mm
 Display: Touch screen
 Power: 700W
 Voltage: 1x208-230 V
 Frequency: 50/60Hz.
 Current: 3amp.
 Air required: Working pressure: 6bar. 120L/min.
 Weight: 205kg.

Available is a wide range of graders, to grade most food products

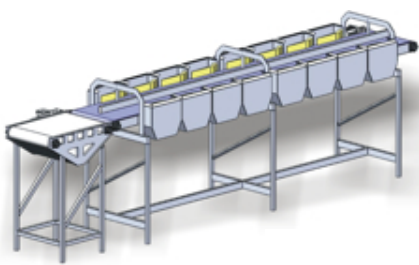

Fresh Product Grader

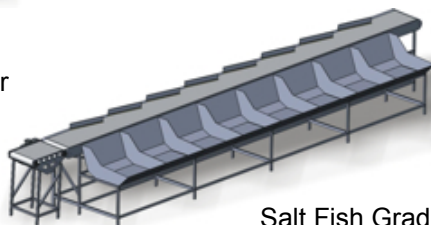

Salt Fish Grader

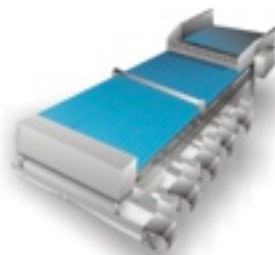

Pelagic Channel Grader



Scallop Channel Grader

Optimize your investment with custom-made solutions

Traust technology, LLC., has been a leader in the development of processing equipment for over 30 years. Our qualified team of engineers, with years of experience, has designed, developed and installed complete processing plants as well as stand alone systems to suit the exact needs of processors around the world

