

Fresh Product Graders

Grades fresh fish & all other food products

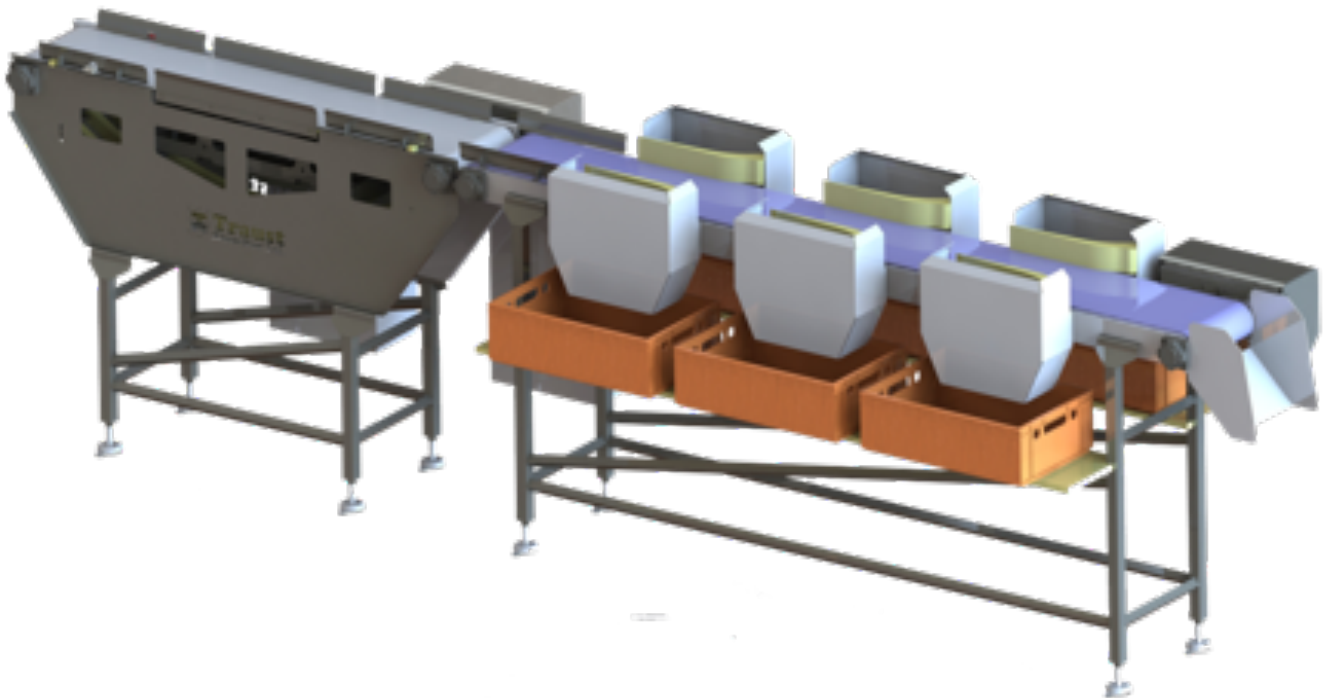

- Easy automatic operation
- Fast & accurate grading
- Simple batching
- High capacity grading
- Safe & easy to operate



Advanced Food Grading

Gentle grading and batching for fish, shellfish, beef, lamb, pork, poultry & other food products



Grading raw material in the beginning of processing improves product handling, performance and yields. The Fresh Product Grader can be used to grade various species directly into holding bin or tub before further processed.

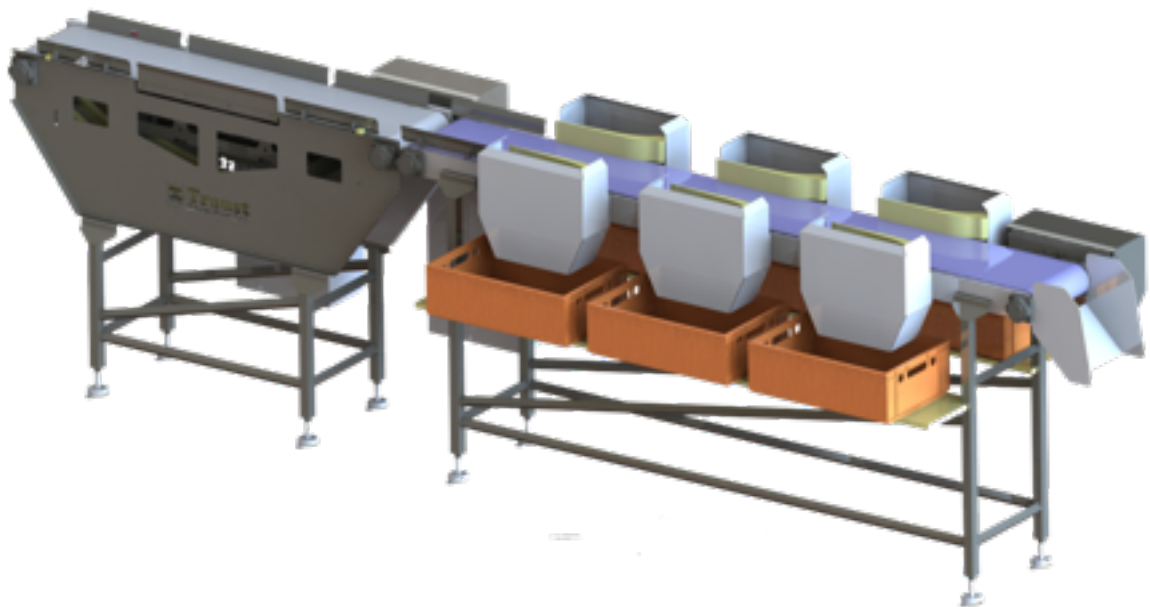

The Fresh Product Grader is a robust and reliable that is capable of withstanding harsh conditions. Operation is simple with a user-friendly touch screen and Ethernet data registration for quality control and traceability. Suitable for grading and simple batching of a wide variety of whole fish species, the grader is designed to fulfill the needs of every food processing operation.

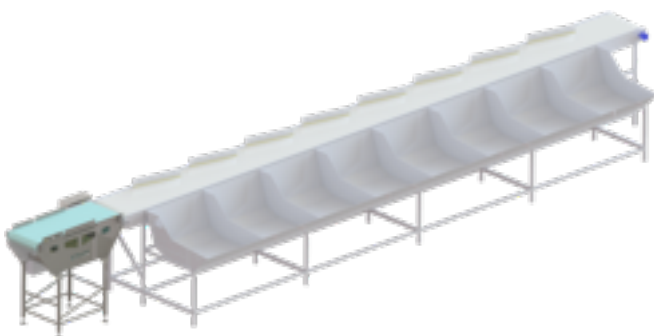

Salt Fish Grader

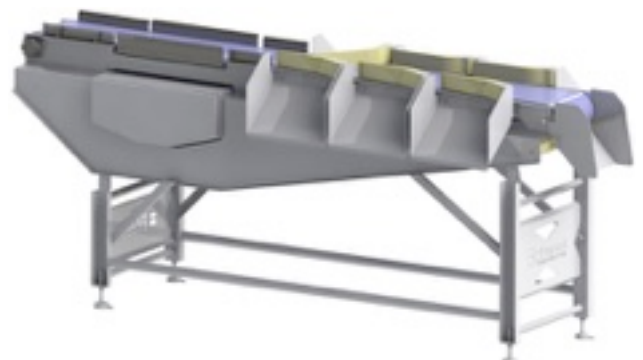

Easy Compact Grader

Standard or customized solution

Accurate fresh fish grading, handles raw material gently
multiple grading capabilities



All Fresh Product Graders are custom built according to customer needs and specification

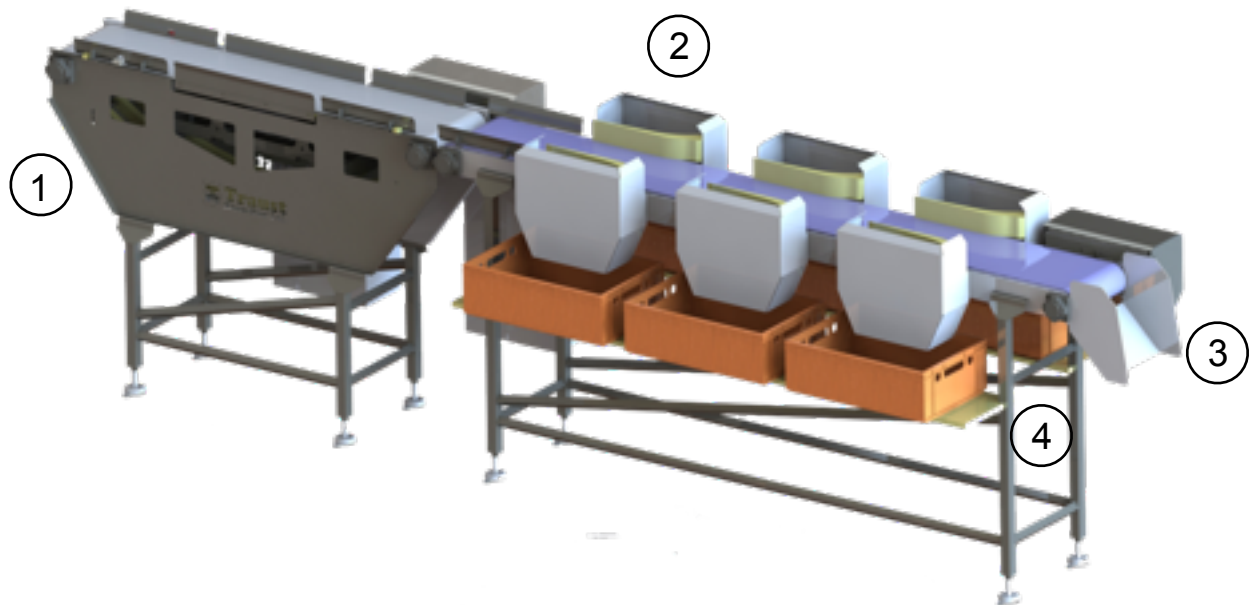

- 1) Flow-scale & user interface
- 2) Grading gates (According to customer Specification)
- 3) Conveyor belt
- 4) Tubs (Not included in grader price)

Benefits:

- Gentle & accurate grading
- Automatic process
- Handles raw material gently
- High capacity grading
- Energy efficient
- Standard solution or customized
- Easy to clean & sanitize
- Safe & easy to operate

Fresh Product Grader FPG100 series

Fresh Product Grader FPG100 grades whole fish into a user defined weight categories. The system's rugged arms quickly swivel out and gently pull each individual piece into the correct chute for its grade. Capacity depends on product size and weight. The grader has user-friendly interface and easy to use, providing a necessary tool for any operation wishing to separate light-weight pieces from the heavier ones, for better processing performance and improved profit. Optional to grade into 1000 Liter plastic tubs or onto takeaway conveyors.

Fresh Product Grader



Optional to grade into 1000 Liter plastic tubs.

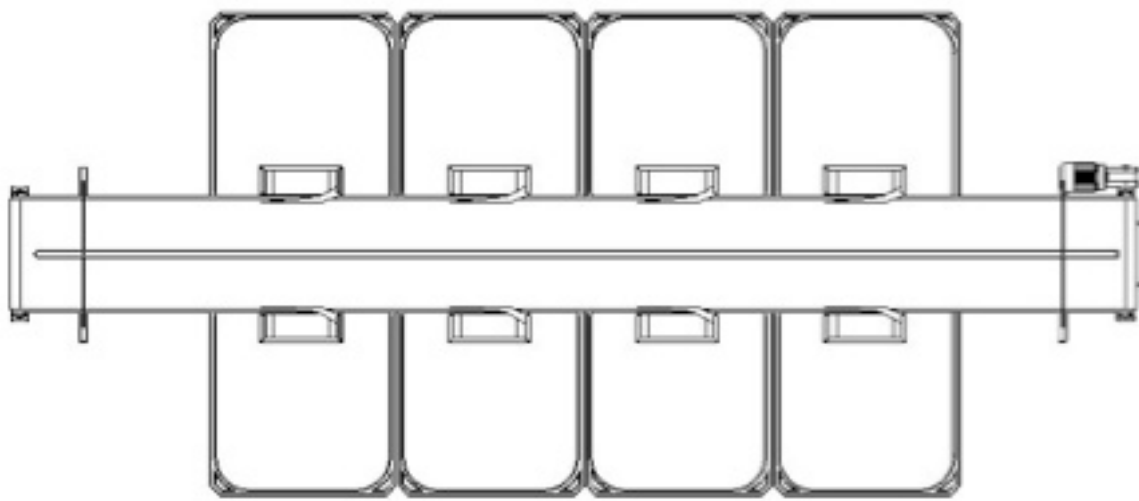
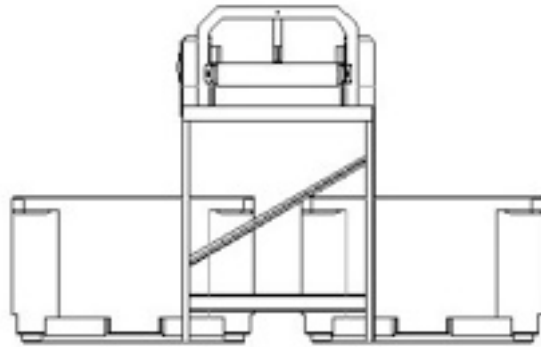

Available is a wide range of graders, to grade most food products

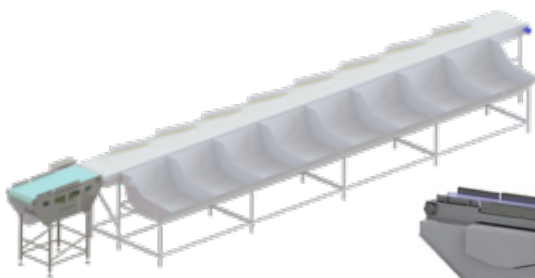

Salt Fish Grader

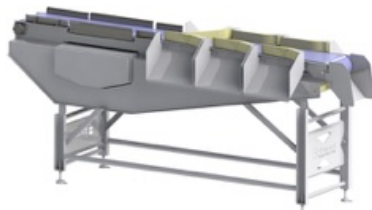

Easy Compact Grader

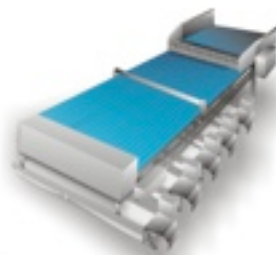

Pelagic Channel Grader



Scallop Channel Grader

Optimize your investment with custom-made solutions

Traust technology, LLC., has been a leader in the development of processing equipment for over 30 years. Our qualified team of engineers, with years of experience, has designed, developed and installed complete processing plants as well as stand alone systems to suit the exact needs of processors around the world

